

CHEMICALLY RESISTANT DIAPHRAGM GAS SAMPLING PUMPS TO ATEX

DATA SHEET E 172



N 726 FTE Ex -
for use in potentially explosive atmospheres, chemically resistant



N 726 FT.29E Ex -
for use in potentially explosive atmospheres, chemically resistant - adjustable flow rate



Concept

The diaphragm gas sampling pumps from KNF are based on a simple principle - an elastic diaphragm, fixed on its edge, moves up and down its central point by means of an eccentric. Thus, the medium is transferred via automatic valves.

The gas-bearing parts of the chemically-resistant gas pumps are made of PTFE, so they are able to withstand even highly aggressive gases and vapors. The N 726 FT.29E Ex with an adjustable flow rate, is for adapting to the current process conditions.

Pumps and pump drives in this product series are explosion proof according to 94/9/EC (ATEX).

Several different drive motors are available.

Features

Pure transferring, evacuation and compression of air, gases and vapors

No contamination of the media due to oil-free operation

Explosion protected to ATEX

Chemically-resistant models

transferring high aggressive and corrosive gases and vapors.

High level of gas tightness:

approx. 6×10^{-3} mbar x l/s

Long product life

Very quiet and little vibration

Cool running motor

even when in constant use

Versions with adjustable flow rate

Can operate in any installed position

Areas of use

The diaphragm pumps offer a high level of performance despite their small size, as well as an excellent price performance ratio. They are required especially in explosive atmospheres in the fields of chemistry industry, environmental, production technology and research.

Beside other applications, pumps are used for gas measurement, for example for sampling gases from the ambient environment, or for exhaust gas and smoke analysis. Easy installation and adaption to a variety of processes.

Performance data

Type	Delivery (l/min)	Vacuum (mbar absolute)	atm. press.	Pressure (bar g)	Weight (kg)
N 726 FT.29E Ex	13	125		1.5	7.5
N 726 FTE Ex	13	53		1.5	7.5

N 726 FTE EX

Performance data

Type	Delivery at atm. pressure (l/min) ¹⁾	Max. operating pressure (bar g)	Ultimate vacuum (mbar abs.)
N 726 FTE Ex	13	1.5	53

¹⁾ Liter at STP

Motor data

	IP 44	IP 44
Protection class	IP 44	IP 44
Voltage (V)	230	3~ 230/400
Frequencies (Hz)	50	50
Power P ₁ (W)	70	70
I _{max} (A)	0.96	0.50/0.29

Pump material

Type	Pump head	Diaphragm	Valves
N 726 FTE Ex	PTFE	PTFE-coated	PTFE

Explosion protected

Type	Pump parts	AC motor	Three-phase AC motor
N 726 FTE Ex	Ex II 2G c IIB T4 X	Ex II 2G Ex e IIC T3 Gb	Ex II 2G Ex e IIC T4 Gb

Pumps suited for gases of the group II C on request

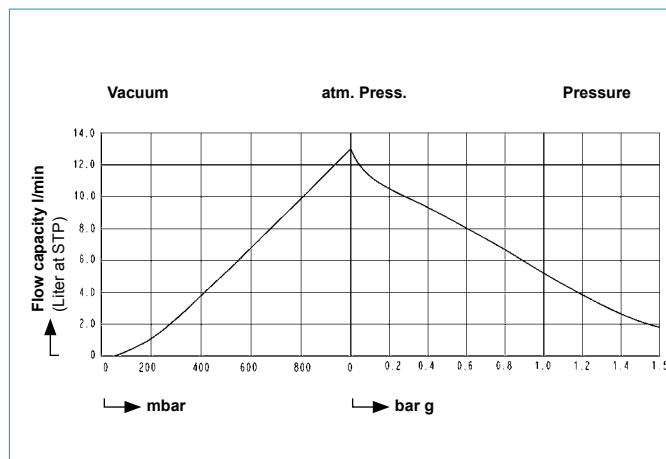
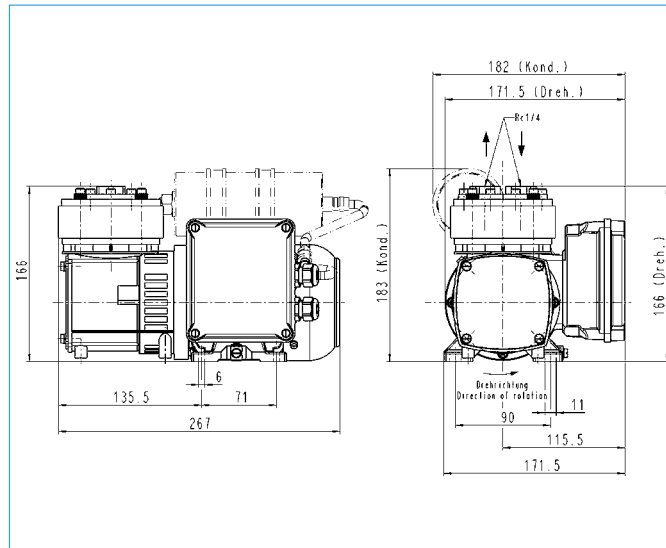

N 726 FT.29E EX

Performance data

Type	Delivery at atm. pressure (l/min) ¹⁾	Max. operating pressure (bar g)	Ultimate vacuum (mbar abs.)
N 726 FT.29E Ex	7 up to 13	up to 1.5	up to 125

Motor data

	IP 44	IP 44
Protection class	IP 44	IP 44
Voltage (V)	230	3~ 230/400
Frequencies (Hz)	50	50
Power P ₁ (W)	70	70
I _{max} (A)	0.96	0.50/0.29

Pump material

Type	Pump head	Diaphragm	Valves
N 726 FT.29E Ex	PTFE	PTFE-coated	PTFE

Explosion protected

Type	Pump parts	AC motor	Three-phase AC motor
N 726 FT.29E Ex	Ex II 2G c IIB T4 X	Ex II 2G Ex e IIC T3 Gb	Ex II 2G Ex e IIC T4 Gb

Pumps suited for gases of the group II C on request

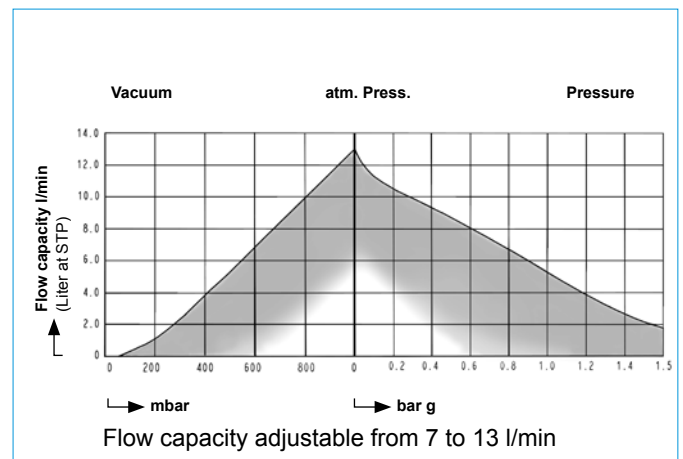
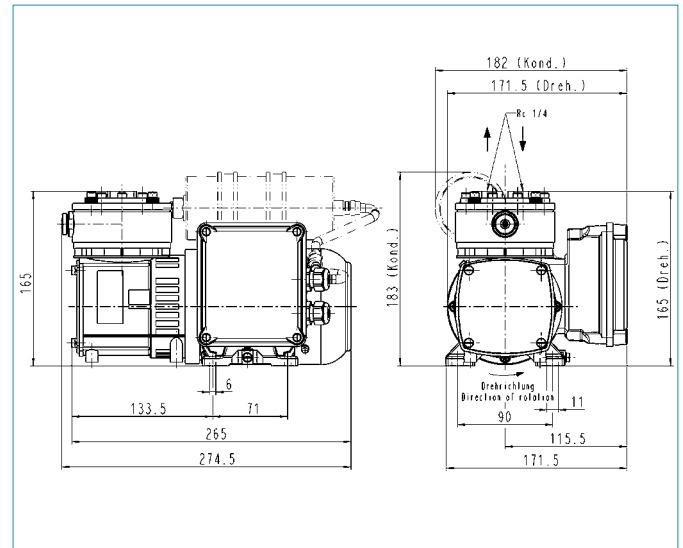

Function of KNF diaphragm gas sampling pumps

An elastic diaphragm is moved up and down by an eccentric (see illustration). On the down-stroke it draws the air or gas being handled through the inlet valve. On the up-stroke the diaphragm forces the medium through the exhaust valve and out of the head. The compression chamber is hermetically separated from the drive mechanism by the diaphragm. The pumps transfer, evacuate and compress completely oil-free.

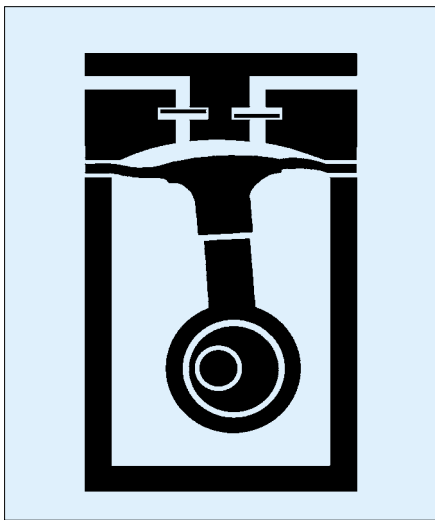

N 726 FT.29E Ex with integral bypass valve

The flow capacity can be adjusted from 7 to 13 liters/minute (at atmospheric pressure and 20 °C), enabling the user to effectively adjust performance to the current process conditions within a system, even while the pump is in operation.

Adjust the pump's performance by loosening the knurled nut **Y** and then turning the adjustment screw **X** to the left (to reduce flow) or to the right (to increase flow). Handtighten the knurled nut **Y** after selecting the desired flow rate.

Hints on installation and operation

- Range of use: Transferring air and gases at temperatures between +5 °C and +40 °C. Use in potentially explosive atmospheres for equipment group II, categories 2 G and 3 G and for authorized gases of group II B (for gases of group II C upon request) up to temperature class T4.
- Permissible ambient temperature: between +5 °C ... +40 °C.
- The pumps are not designed to start against pressure or vacuum; when a pump is switched on the pressure in the suction and pressure lines must be atmospheric. Pumps that start against pressure or vacuum are available on request.
- To prevent the maximum operating pressure being exceeded, restriction or regulation of the air flow should only be carried out in the suction line.
- Components connected to the pump must be designed to withstand the pneumatic performance of the pump.
- Install the pump so that the fan can draw in sufficient cooling air.
- Fit the pump at the highest point in the system, so that condensate cannot collect in the head of the pump - that prolongs working-life.

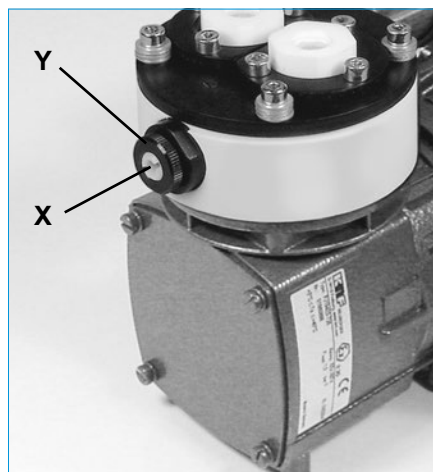

Diaphragm pumps conforming to 94/9/EC (ATEX) for use in potentially explosive atmospheres

ATEX - The new standard for explosion protection as part of the new single market, the regulations on explosion prevention and protection have now been unified throughout Europe.

The legal requirements are set out in the directive 94/9/EC (also known as ATEX). In Germany, the directive was passed into national law on March 1st, 1996.

Compared to the previous legal requirement, the scope of the regulations have now been extended: whereas the old regulations were concerned with electrical equipment, mechanical equipment is now also included. For pumps, this means that besides the drive section (drive motor, an electrical device), the working section (pump part, a non-electrical device) now also falls within the regulations.

The explosion prevention and protection requirements depend on the specific equipment group and the relevant equipment category. Rather than concrete requirements, the directive formulates the assurance of protection levels, thus placing greater responsibility than before on the product manufacturer.

What KNF offers

KNF offers transfer pumps, vacuum pumps and compressors for

- Equipment group II and
- category 2 G (for gases, vapors and mists where explosive atmospheres are likely to occur) and 3 G (for gases, vapors and mists where explosive atmospheres are unlikely to occur or, if they do occur, are likely to do so only infrequently and for a short period only)
- approved gases the group of II B, temperature up to class T4

KNF Neuberger GmbH Pumps + Systems

Alter Weg 3
D-79112 Freiburg, Germany
Tel. +49 7664 5909 0
Fax +49 7664 5909 99
info@knf.de
www.knf.de